

**P.15.04.4***Acta Cryst.* (2005). **A61**, C432**A Three-block X-ray Monolite Resonator**

Ruben Ts. Gabrielyan, A. H. Toneyan, *Yerevan State University A. Manookian str. 1 Yerevan Armenia, 375*. E-mail: rugab@ysu.am; albert@r.am

An X-Ray Resonator for Silicon single crystal (440, 404) configuration's  $\text{NiK}\alpha_2$  -radiation is offered and principally carried out. Asymmetric reflections (where reflecting planes consist  $30^\circ$  angle with block planes) were used. In contrast to [1], the incident beam enters the resonator and undergoes a closed cycle only through Bragg's reflections. The device was moving by a scanning mechanism perpendicular to the incident beam, and it made possible to take out of the resonator the beams reflected 1,2,3...times and detect them (Fig. 1). It is obvious that there exists a position in which the beam stays in the resonator, providing a closed cycle (Fig. 2). The device will give its best results in the case of synchrotron radiation, for in this case it is possible to choose a precise wavelength

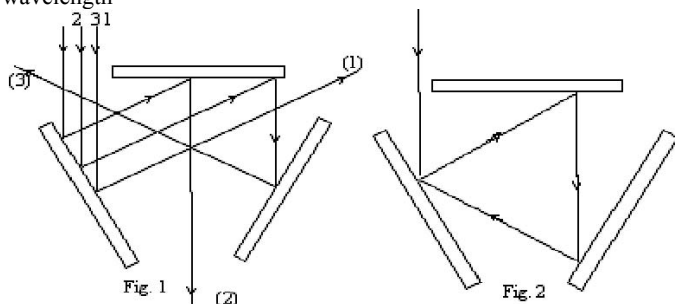

[1] Deslattes R.D., *Appl. Phys. Letters*, 1968, **12**, 133.

**Keywords:** X-ray resonator, diffraction, monochromator

**P.15.06.1***Acta Cryst.* (2005). **A61**, C432**ATS Scattering from Isomorphic and Polymorphic Crystals**

Kohtaro Ishida, Jun Kokubun, *Department of Physics, Tokyo University of Science, Noda, Japan*. E-mail: ishida@ph.noda.tus.ac.jp

The ATS scattering [1] is X-ray resonant scattering caused by the anisotropic terms of susceptibility. It can be observed in forbidden reflections near the absorption edge. It reveals the nature of empty electron-states of the atoms/ions in a crystal. We observed the scattering from pyrite structure, ( $\text{FeS}_2$ ,  $\text{NiS}_2$ ,  $\text{CoS}_2$ ), spinel structure ( $\text{Fe}_3\text{O}_4$ ,  $\text{ZnFe}_2\text{O}_4$ ,  $\text{NiFe}_2\text{O}_4$ ), corundum structure ( $\text{Fe}_2\text{O}_3$ ,  $\text{Cr}_2\text{O}_3$ ), and polymorphic crystals of  $\text{TiO}_2$ , rutil, anatase and brookite [2-5]. From experiments, we obtain following results. The scattering observed above the edges is caused by the dipole transition. The peaks in the pre-edge are caused by transitions through higher order terms. In the pyrite type, the energy spectra above the edges are similar to each other in spite of different ions. There are no peaks above the edges in a corundum type because the dipole transition is forbidden by the symmetry. In the pre-edge, hematite has a resonant peak, however eskolaite has a peak with a shoulder. The peaks show three (hematite) and six-fold (eskolaite) azimuthal dependence. They are explained by the quadrupole-dipole and the quadrupole transition. The ATS scattering in polymorphic crystals of  $\text{TiO}_2$  shows their own properties determined by the site symmetry of them. The energy spectra are different from each other though the absorption curves are similar.

[1] Dmitrienko V.E., *Acta Cryst.*, 1983, **A39**, 29. [2] Nagano T., et al., *J. Phys. Soc. Jpn.*, 1996, **65**, 3060. [3] Hagiwara V., et al., *J. Phys. Soc. Jpn.*, 1999, **68**, 1592. [4] Kokubun J., et al., *J. Phys. Soc. Jpn.*, 1998, **67**, 3114. [5] Kanazawa M., et al., *J. Phys. Soc. Jpn.*, 2002, **71**, 1765.

**Keywords:** X-ray resonant scattering, forbidden reflection, quadrupole transition

**P.15.06.2***Acta Cryst.* (2005). **A61**, C432**Anisotropic Resonant X-ray Scattering from Antiferromagnet Hematite,  $\text{Fe}_2\text{O}_3$** 

Jun Kokubun<sup>a</sup>, Kohtaro Ishida<sup>a</sup>, Vladimir E. Dmitrienko<sup>b</sup>, <sup>a</sup>*Faculty of Science and Technology, Tokyo University of Science, Japan*. <sup>b</sup>*A. V. Shubnikov Institute of Crystallography, Moscow, Russia*. E-mail: kokubun@ph.noda.tus.ac.jp

Hematite has a corundum structure with antiferromagnetic moments perpendicular to rhombohedral [111] at room temperature. At the Morin temperature ( $T_M = 250$  K) their directions change parallel. Anisotropic resonant scattering from hematite was first observed by Finkelstein et al.[1] We have investigated more detailed property of the resonant *forbidden* reflections 111 and 333.[2]

The experiment was carried out near the Fe K-absorption edge with synchrotron radiation source. We measured the energy spectra of the 111 and 333 forbidden reflections intensities. Both spectra show one peak in the pre-edge region and small non-resonant intensity. The azimuthal angle dependence of the forbidden reflections measured at the non-resonant energy shows twofold pattern, which can be explained by non-resonant magnetic scattering. At the resonant energy, however, the azimuth dependence of the 111 reflection shows threefold symmetry. This character is interpreted as a result of interference between electric dipole-quadrupole and quadrupole-quadrupole transition effect. The azimuth dependence of the 333 reflection at the resonant energy scarcely shows threefold symmetry in spite of manifest threefold pattern below the  $T_M$ . We conclude that the resonant 333 reflection is affected by resonant magnetic scattering.

[1] Finkelstein K.D., Shen Q., Shastri S., *Phys. Rev. Lett.*, 1992, **69**, 1612. [2] Kokubun J., Ishida K., *Photon Factory Act. Rep.*, 2002, **20A**, 21.

**Keywords:** X-ray resonant scattering, X-ray magnetic scattering, antiferromagnetism

**P.15.06.3***Acta Cryst.* (2005). **A61**, C432**Near-Edge Forbidden Reflections in Resonant Diffraction by Modulated Crystals**

Elena N. Ovchinnikova<sup>a</sup>, Vladimir E. Dmitrienko<sup>b</sup>, Luca Bindi<sup>c</sup>, Yuji Soejima<sup>d</sup>, <sup>a</sup>*Moscow State University, 119899 Russia*. <sup>b</sup>*Institute of Crystallography, Moscow, Russia*. <sup>c</sup>*University of Florence, Italy*. <sup>d</sup>*Kyushu University, Japan*. E-mail: ovchin@yahoo.co.uk

High sensitivity of the atomic tensor factor near absorption edges to the displacements of both resonant and neighbouring atoms can provide additional reflections in resonant X-ray diffraction by incommensurately modulated crystals. In the presence of modulation the local symmetry of each resonant atom becomes lower than in the basic structure, hence additional tensor elements can appear. In this report, some calculations of the structure factors are presented for the Co-åkermanite taking into account what already known [1] about its two-dimensional modulation. Co atoms, in the corresponding basic structure, are in the (2a) sites with  $\bar{4}m$  symmetry of the  $P\bar{4}2_1m$  space group, which make it impossible to obtain any forbidden reflections near Co K-edge in the dipole-dipole approximation. However, the main reflections  $h00$ ,  $h=2n+1$  corresponding to the basic structure can appear near Co K-edge owing to the dipole-quadrupole contribution. We showed that the displacement terms in the anisotropic tensor factor could mainly contribute to the first order satellites, providing the forbidden reflections satellites near the Co K-edge with  $hhl m0$ ,  $m=2n+1$  or  $h00 m$ ,  $h=2n+1$ .

This work was partly supported by INTAS grant 01-0822.

[1] Hagiya K., Kusaka K., Masaaki O., Iishi K., *Acta Cryst.*, 2001, **B57**, 271.

**Keywords:** X-ray anisotropy, incommensurate crystals, satellites

**P.15.06.4***Acta Cryst.* (2005). **A61**, C432-C433**Thermal-motion-induced Forbidden Resonant Scattering: Experiment vs Theory**

Vladimir E. Dmitrienko<sup>a</sup>, E. N. Ovchinnikova<sup>b</sup>, K. Ishida<sup>c</sup>, J. Kokubun<sup>c</sup>, A. Kirfel<sup>d</sup>, S.P. Collins<sup>e</sup>, D. Laundy<sup>f</sup>, A.P. Oreshko<sup>b</sup>, D. Cabaret<sup>g</sup>, Y. Joly<sup>h</sup>, V.L. Kraizman<sup>i</sup>, A.A. Novakovich<sup>i</sup>, E.V. Krivitskii<sup>i</sup>, R.V. Vedrinskii<sup>i</sup>, <sup>a</sup>*Institute of Crystallography, Moscow, 119333 Russia*. <sup>b</sup>*Moscow State University, Russia*. <sup>c</sup>*Tokyo University of Science, Japan*. <sup>d</sup>*Bonn University, Germany*. <sup>e</sup>*Diamond Light*